

EEx d/de flameproof motors

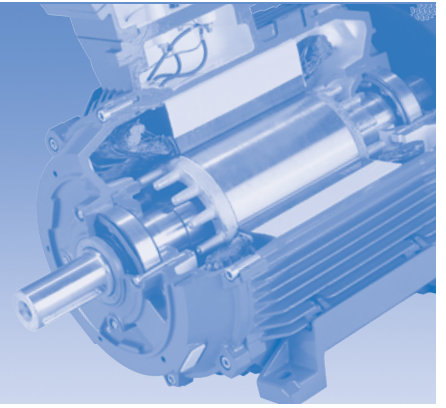

Frames 90 - 315L

EEx d/de flameproof motors

90 - 315L

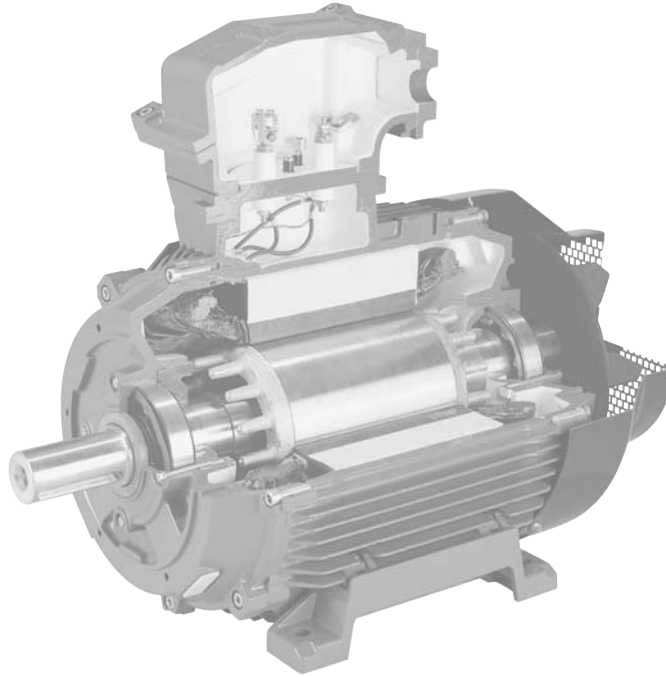

Brook Crompton

Brook Crompton is a leading manufacturer of electric motors for the global industrial market, with motor solutions which benefit a wide range of customers.

Our products are used in almost every industrial activity including water treatment, building services, chemical/petrochemicals, general processing and manufacturing where they drive fans, pumps, compressors and conveyors, amongst other things.

Brook Crompton incorporates many well known names including Brook Motors, Crompton Parkinson, Electrodrives, Newman, Bull Electric and Hawker Siddeley Electric Motors.

We have extensive stocks of motors around the world, backed-up by a network of distributors, ensuring excellent local support wherever needed.

Quality assurance

Stringent quality procedures are observed from first design to finished product in accordance with the ISO9001 documented quality systems.

Our factories have been assessed to meet these requirements, a further assurance that only the highest possible standards of quality are accepted.

EEx d/de flameproof motors

Brook Crompton has one of the widest available ranges of electric motors for operation in hazardous atmospheres and hostile environments.

We have over 90 years' technical and design experience in this most specialised market and are able to ensure the correct selection of motors for any application, taking into full account the two most important factors to be considered - safety and economy.

Brook Crompton's range of EEx d/de motors are designed, tested and manufactured in accordance with the latest Euronorm and relevant country standards.

Motors are manufactured in factories that are assessed by a European notified body (eg Baseefa (2001) Ltd, PTB), meeting rigorous quality controls.

Efficiency

Brook Crompton are an approved manufacturer of ac electric motors within the UK Government's Enhanced Capital Allowance scheme (ECA). A wide range of single and multi-speed motors are included on the UK Energy Technology List. Please check the ECA scheme website: www.eca.gov.uk at time of purchase for current listing.

Benefits include:

- Baseefa (2001) Ltd certified
- Full 2-year guarantee
- Stainless steel rating and certification plate
- Certification for inverter use
- Certificate of Grant of Patent on the bearing cap
- IP55 protection

ATEX

All EEx d/de motors fully comply with the requirements of the ATEX Directive (94/9/EC).