

# Mueller Steam Specialty

| WORKING PRESSURES - NON-SHOCK<br>in accordance with ANSI B 16.5-1981 |                   |
|--|-------------------|
| Steam  | WOG               |
| 150 PSI @ 565 ° F  | 250 PSI @ 100 ° F |
| 10.3 BARS-296 ° C  | 17.2 BARS-38 ° C  |

Model: 758-N

## Cast Iron Flanged "Y" Strainers

**758-N**

**Class 150**



Model 758-N

### SERVICE RECOMMENDATIONS

The 758-N "Y" strainer is recommend for use in water, oil, gas and steam piping to prvide economical protection for pumps, meters, valves, compressors, traps and similar equipment.

### SCREENS

Standard screens for 758-N are perforated 304 stainless steel with spot welded seam. Perforated monel and other alloys are available as an option. Mesh lining is available in all alloys for extra fine straining. Recommended standard perforations are listed below.

|         |              |                 |
|---------|--------------|-----------------|
| 3/4"-4" | .062 (1/16") | Water, Oil, Gas |
| 5"-12"  | .125 (1/8")  |                 |
| 14" up  | .25 (15/64") |                 |
| 2"-10"  | .045 (3/64") | Steam           |
| 12"     | .062 (1/16") |                 |

Consult factory for other applications

### CONSTRUCTION

All covers have an NPT blowoff outlet at location "C". Recessed seat in the cover assures accurate screen alignment. Bosses at the inlet anc outlet flanges are provided for gage taps. See page C-2 for pressure drop information.

### SELF CLEANING

Self cleaning is done by opening the valve or plug connected to the blowoff outlet. Advise when strainers are tobe mounted in vertical piping so we can rotate the cover to position the blowoff at the lowes point.

### BLOWOFF OUTLETS

Tapped NPT, sizes specified in the dimensiom table. Blowoff outlets are not normally furnished with plugs.

### INDIVIDUALLY HYDROSTATICALLY TESTED.

### MATERIALS:

Body                   Cast iron, ASTM A126-B  
 Cover                  Cast iron, ASTM A126-B  
 Flat Gasket         Flexible Graphite, Spiral Wound  
 (Consult factory for other materials)



**Mueller Steam Specialty**

1491 N.C. Hwy 20 West, St. Pauls, NC 28384

# Mueller Steam Specialty

## Dimensions and Weights

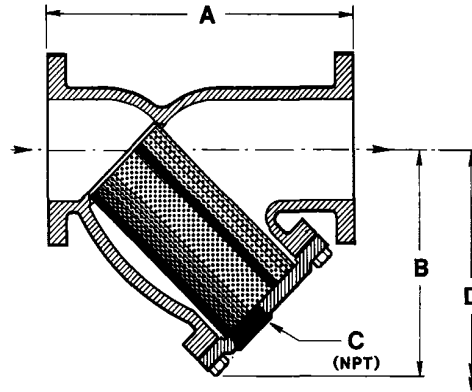

Model 758-N

| size                       | in | 3/4"  | 1"    | 1-1/4" | 1-1/2" | 2"    |
|----------------------------|----|-------|-------|--------|--------|-------|
|                            | mm | 20    | 25    | 30     | 40     | 50    |
| <b>A</b>                   | in | 7-3/8 | 7-3/8 | 7-1/2  | 7-1/2  | 9     |
|                            | mm | 187   | 187   | 190    | 190    | 227   |
| <b>B</b>                   | in | 3-3/4 | 3-7/8 | 4-3/4  | 4-3/4  | 5-1/2 |
|                            | mm | 95    | 98    | 120    | 120    | 140   |
| <b>C</b><br>(NPT)          | in | 1/2   | 1/2   | 1/2    | 1/2    | 1/2   |
|                            | mm | 15    | 15    | 15     | 15     | 15    |
| <b>D</b><br>screen removal |    | 5     | 5     | 6-1/2  | 6-1/2  | 8-1/4 |
|                            |    | 127   | 127   | 165    | 165    | 210   |
| <b>WEIGHTS</b>             |    |       |       |        |        |       |
|                            | lb | 10    | 10    | 13     | 13     | 18    |
|                            | kg | 4.5   | 4.5   | 5.9    | 5.9    | 8     |

| size                       | in | 2-1/2" | 3"     | 4"     | 5"     | 6"     | 8"     | 10"    | 12"    | 14"    | 16"    | 18"    | 20"     |
|----------------------------|----|--------|--------|--------|--------|--------|--------|--------|--------|--------|--------|--------|---------|
|                            | mm | 65     | 80     | 100    | 125    | 150    | 200    | 250    | 300    | 350    | 400    | 450    | 500     |
| <b>A</b>                   | in | 10-5/8 | 11-1/2 | 13-3/4 | 16-3/8 | 18-1/2 | 21-1/2 | 26     | 30     | 37-3/8 | 39-3/8 | 41-1/8 | 43-5/16 |
|                            | mm | 270    | 291    | 350    | 416    | 470    | 545    | 661    | 764    | 950    | 1000   | 1044   | 1100    |
| <b>B</b>                   | in | 7-1/4  | 8-1/4  | 9-1/4  | 11     | 12-5/8 | 14-5/8 | 18-3/4 | 21-1/4 | 26-3/8 | 29-3/4 | 32-1/2 | 35-7/16 |
|                            | mm | 185    | 210    | 235    | 280    | 320    | 370    | 475    | 540    | 670    | 756    | 825    | 900     |
| <b>C</b><br>(NPT)          | in | 1      | 1      | 1-1/2  | 2      | 2      | 2      | 2      | 2      | 2      | 2      | 2      | 2       |
|                            | mm | 25     | 25     | 40     | 50     | 50     | 50     | 50     | 50     | 50     | 50     | 50     | 50      |
| <b>D</b><br>screen removal |    | 11     | 11-3/4 | 12-5/8 | 14-1/8 | 17     | 21-1/4 | 27-5/8 | 32-1/4 | 35-1/2 | 41-3/4 | 46-1/2 | 53-1/8  |
|                            |    | 280    | 300    | 320    | 360    | 430    | 540    | 700    | 820    | 900    | 1060   | 1180   | 1350    |
| <b>WEIGHTS</b>             |    |        |        |        |        |        |        |        |        |        |        |        |         |
|                            | lb | 28     | 34     | 60     | 95     | 133    | 247    | 370    | 579    | 863    | 1380   | 2272   | 3890    |
|                            | kg | 12     | 15     | 27     | 43     | 60     | 112    | 168    | 263    | 392    | 627    | 1032   | 1768    |

Approximate Dimensions and Weights. Apply For Certified Drawings.



**Mueller Steam Specialty**

1491 N.C. Hwy 20 West, St. Pauls, NC 28384