

MUELLER FLOW CONTROL CAST IRON GATE VALVE FLANGED END

Model: 0125-F

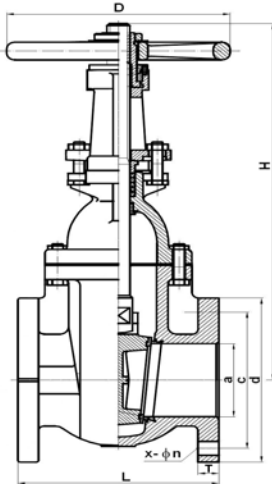

Standard and Application

1	MSS-SP-70: Design according to MSS-SP-70, Flanged and face to ANSI B16.10 Class 125
2	For water, industry waste water, oil and gas.

Pressure Test

		MSS-SP-70
Working pressure:		200 PSI
Test Pressure	Shell	350 PSI
	Seat	220 PSI
Maximum Temperature:		150°C

Part List

PARTS	MSS-SP-70
Body, Bonnet, Disc, Gland flange, Hand wheel	Cast iron ASTM A126 B
Body seat ring	Cast brass or cast bronze
Disc seat ring	
Yoke sleeve	Brass or bronze
Stem	Stainless steel/Brass
Stud bolt & nut	Carbon Steel
Wheel nut	Carbon Steel/brass
Taper pin	Carbon Steel
Gland packing	Graphite
Gasket	SS+Graphite

Ductile Iron Material Available

Dimensions

		(mm)					
Size Inch	a	D	ANSI B16.10		125PSI		c
			L	H(Open)	d	x - φ n	
2"	50	180	177.8	330	152	4- φ19	120.7
2-1/2"	65	180	190.5	385	178	4- φ19	139.7
3"	80	200	203.2	420	191	4- φ19	152.4
4"	100	200	228.6	500	229	8- φ19	190.5
5"	125	250	254.0	660	254	8- φ22	215.9
6"	150	280	266.7	740	279	8- φ22	241.3
8"	200	300	292.1	930	343	8- φ22	298.5
10"	250	400	330.2	1228	406	12- φ25	362.0
12"	300	457	355.6	1373	483	12- φ25	431.8
14"	350	508	381.0	1595	533	12- φ29	476.3



Mueller Flow Control

© Registered Trade Mark

MUELLER FLOW CONTROL CAST IRON GATE VALVE FLANGED END

Materials

Outside screw and yoke, Bolted bonnet solid wedge disc,
Bronze trimmed, Flanged ends.

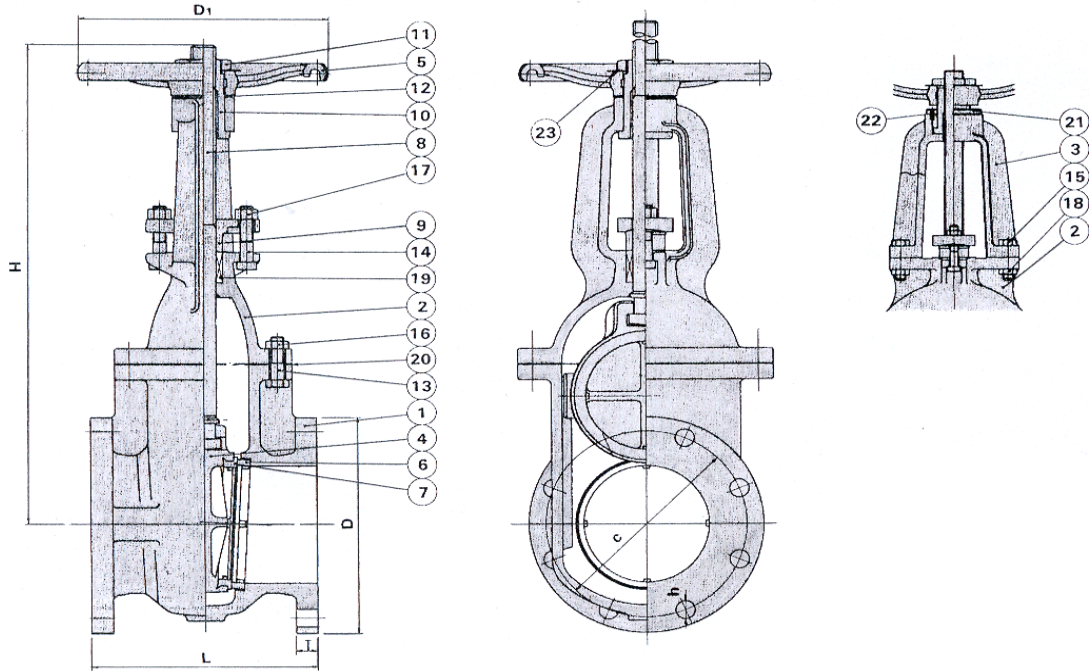

Model: 0125-F

Materials

No.	Name of parts	ASTM Specifications	
1	Body	Cast iron	A126 Class B
2	Bonnet	Cast iron	A126 Class B
3	Yoke	Cast iron	A126 Class B
4	Disc	Cast iron	A126 Class B
5	Handwheel	Cast iron	A126 Class B
6	Body seat ring	Cast bronze	B62-C83600
7	Disc seat ring	Cast bronze	B62-C83600
8	Stem	Forged brass	B124-C37700
9	Gland	Cast iron	A126 Class B
10	Yoke sleeve	Cast bronze	B62-C83600
11	Wheel nut	Steel*	A36
12	Washer	Brass plate	B36-C26000
13	Bonnet bolt	Steel*	A307 Grade B
14	Gland bolt	Steel*	A307 Grade B
15	Yoke bonnet bolt	Steel*	A307 Grade B
16	Bonnet bolt nut	Steel*	A563 Grade A
17	Gland bolt nut	Steel*	A563 Grade A
18	Yoke bonnet nut	Steel*	A563 Grade A
19	Gland packing	Graphite	
20	Gasket	SS+Graphite	
21	Sleeve nut	Cast iron	A126 Class B
22	Knock pin	Steel*	A36
23	Name plate	Aluminium plate	B209-110

*Zinc plated



Mueller Flow Control

® Registered Trade Mark